

### OBKIT1

#### BULLHORN STYLE OUTBOARD KIT

Complete with:-  
1 x 401N8 helm  
1 x 211BH cylinder  
2 litres ULTRA-15  
15M nylon hydraulic tubing  
Fittings  
Bleeding kit  
Instructions



### COMKIT1

#### BULLHORN STYLE OUTBOARD KIT

Complete with:-  
1 x 501N8 helm  
1 x 511BH cylinder  
2 litres ULTRA-15  
15M nylon hydraulic tubing  
Fittings  
Bleeding kit  
Instructions



### COMKIT1-PRO

#### BULLHORN STYLE OUTBOARD KIT

Complete with:-  
1 x 401N8 helm  
1 x 511BH cylinder  
2 litres ULTRA-15  
15M nylon hydraulic tubing  
Fittings  
Bleeding kit  
Instructions



### COMKIT6

#### BULLHORN STYLE OUTBOARD KIT

Complete with:-  
1 x 501N8 helm  
1 x 512BH cylinder  
2 litres ULTRA-15  
15M nylon hydraulic tubing  
Fittings  
Bleeding kit  
Instructions



### COMKIT5

#### FRONT MOUNT Style OUTBOARD KIT

Complete with:-  
1 x 501N8 helm  
1 x 516FM cylinder  
2 litres ULTRA-15  
15M nylon hydraulic tubing  
Fittings  
Bleeding kit  
Instructions



Selection of the most suitable steering system for your boat is a simple matter of:-

1) Matching the HP of your outboard to the recommended capacity of the steering system. *Note: with the COMKIT6 which has a rated maximum capacity of 150HP motor, the optimum performance is from 40HP-120HP for comfortable handling. You should consider the COMKIT1 for higher HP motors for lightest control.*

2) Deciding which TYPE of cylinder best suits your engine-well.

3) Considering your budget as to whether you want to go for the normal pleasure rated system or invest in the top-of-the-range commercial system.

## TYPES

**BULLHORN** type steering is by far the most popular steering system for outboard motors as it is compact, simple to install and requires the minimum amount of clearance in an engine well.

**FRONT MOUNT** type steering is also popular because of the lower cost, combined with the fact that the hoses are in a fixed position and do not move. The disadvantage is the amount of space required in the engine well due to the piston rod travelling in each direction.

## SERIES

The **Commander** Series (COMKIT models) are designed for use on pleasure boats only with outboard motor Horsepower limitations as shown. They utilise a state-of-the-art aluminium cylinder design, with unique electrolytic insulation between metals for maximum corrosion resistance. The **PRO** versions are designed for both pleasure and commercial use

The **Admiral** Series (OBKIT models) are designed for the most robust operation in both pleasure and commercial vessels and offer the strongest and most corrosion resistant steering cylinders on the market. There is no equivalent of these cylinders available from any other manufacturer.

## MATCHING YOUR OUTBOARD TO THE CORRECT CYLINDER TYPE AND STYLE

Manufactured in Australia, HyDrive continues to manufacture the highest quality steering systems to suit the ever changing designs and developments in outboard motors. The following chart should be used as a guide to select the correct kit to match your motor(s). If in doubt, contact your nearest HyDrive distributor.

# Selection of steering for OUTBOARDS - SIDE-MOUNT STYLE

## SPORTKIT OUTBOARD KIT

Complete with:-  
 1 x 401N8 helm  
 1 x 212T cylinder  
 2 litres ULTRA-15  
 15M nylon hydraulic  
 tubing  
 Fittings  
 Bleeding kit

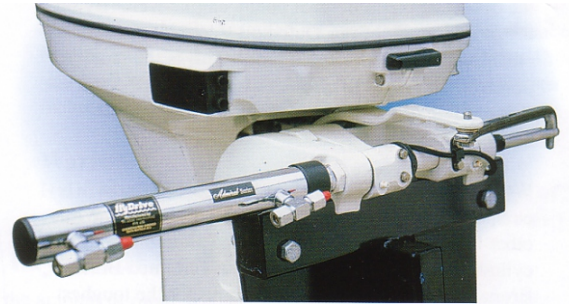

Typical side-mount installation using 210TSE

## SIDE-MOUNT or TUBE-MOUNT

The Side or Tube-mount type cylinders are very popular because of the ease of fitting and the economical price which allows a very simple upgrade from cable steering to hydraulic for vastly improved results.

Selection of this type of steering is entirely dependent on the HP of the outboard(s) as the type of mount is universal to all brands and HP of motors that are fitted with tilt-tubes. Some very small outboards do not have tilt-tubes and therefore must use the same pivoting bracket that is attached to the customer's current cable.

Fitting is very simple as the hydraulic cylinder screws directly onto the threaded tilt-tube in the same location as the existing cable steering. It connects to the tiller arm of the outboard using the standard drag-link already connecting the cable.

### ADVANTAGES

- Low cost system
- Ease of fitting
- Hoses remain stationary

### DISADVANTAGES

The amount of side-clearance required.

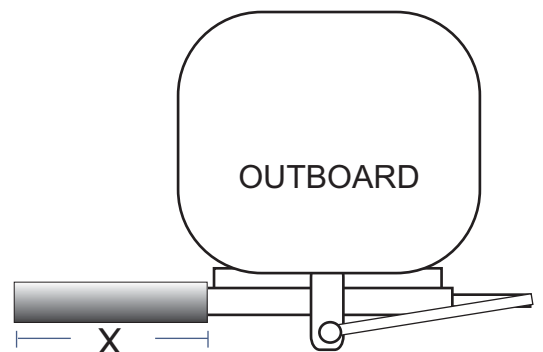

### Side Clearance requirements

- Model 210T (balanced) - 540mm ( 21.2")
- Model 210TSE - 330mm (13")
- Model 212T/512T - 315mm (12.4")

## COMKIT-SPORT OUTBOARD KIT

Complete with:-  
 1 x 501N8 helm  
 1 x 212T cylinder  
 2 litres ULTRA-15  
 15M nylon hydraulic  
 tubing  
 Fittings  
 Bleeding kit  
 Instructions



## OBKIT-2 OUTBOARD KIT

Complete with:-  
 1 x 401N8 helm  
 1 x 210T cylinder  
 2 litres ULTRA-15  
 15M nylon hydraulic  
 tubing  
 Fittings  
 Bleeding kit



## OBKIT-3 OUTBOARD KIT

Complete with:-  
 1 x 401N8 helm  
 1 x 210TSE cylinder  
 2 litres ULTRA-15  
 15M nylon hydraulic  
 tubing  
 Fittings  
 Bleeding kit



# BASIC DIMENSIONS AND CLEARANCE REQUIREMENTS FOR CYLINDERS

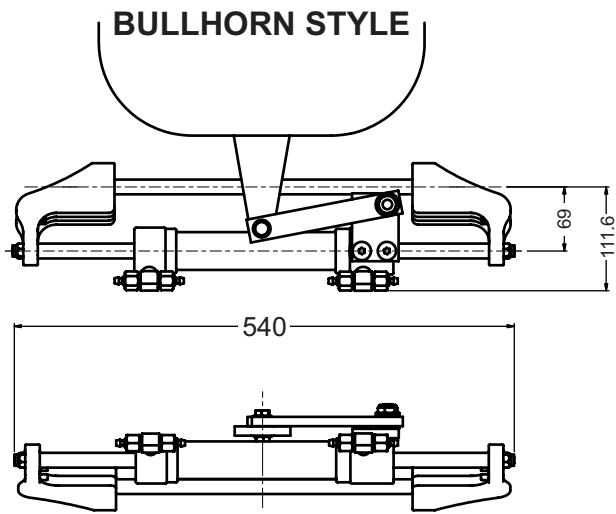

Models 211BH & 511BH  
OBKIT1 & COMKIT-1

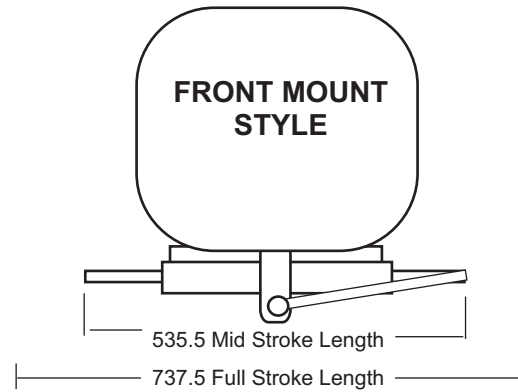

Models 216FM & 516FM  
OBKIT5 & COMKIT-5

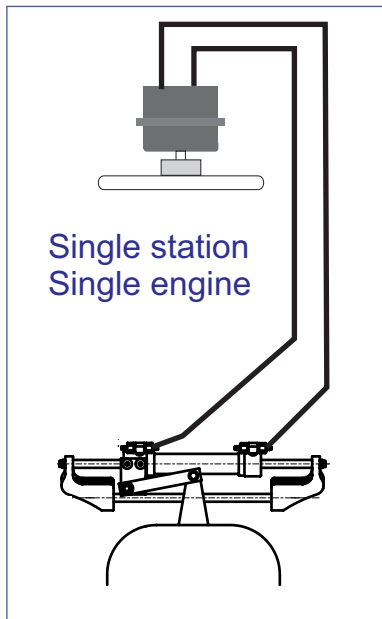
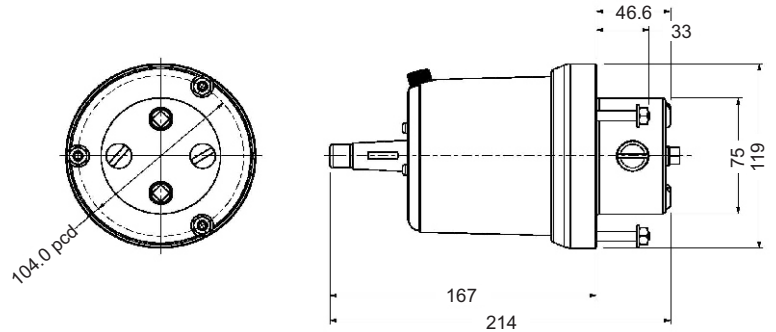

Typical installation  
circuits

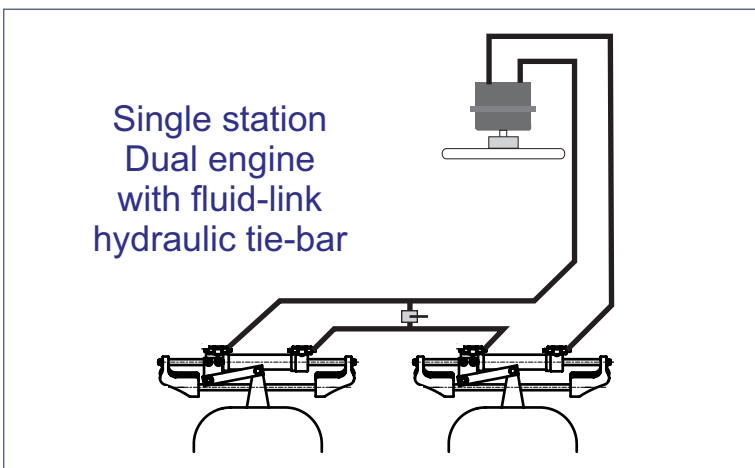
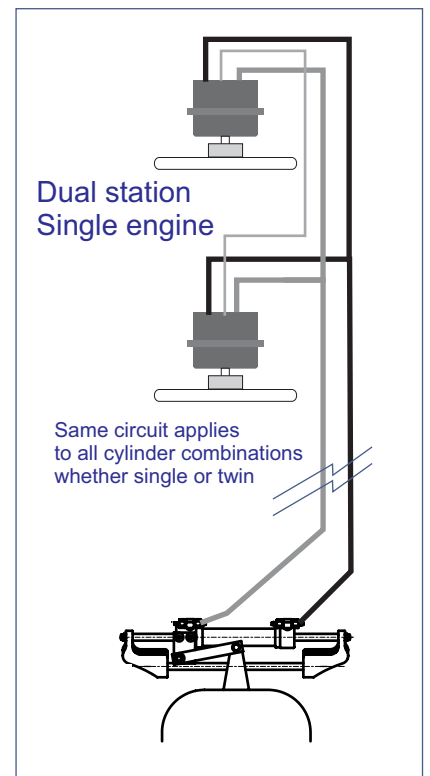

**HYDRAULIC BOAT STEERING**

# HYDRIVE MODEL SELECTION - OUTBOARD MOTORS ONLY

**Note:- The model COMKIT6 can be used in place of the COMKIT1 on all SINGLE motors up to 150HP maximum.  
Optimum performance range for comfortable wheel effort on COMKIT6 is 40HP - 120HP  
The same version should be used as indicated in the listed options - Honda, Mercury etc.**

BRAND	YEAR	MOTOR	HP	HYDRIVE KIT OPTIONS	NOTES
JOHNSON EVINRUDE	ALL YEARS	2 Stroke Single	up to 200HP	Budget - COMKIT1 Bullhorn style Admiral-OBKIT1 Bullhorn style Budget - COMKIT5 Front-mount style Admiral- OBKIT5 Front-mount style	
		2 Stroke Single	up to 300HP	Budget - COMKIT1- <b>PRO</b> Bullhorn style Admiral-OBKIT1 Bullhorn style	
		2 Stroke Twin counter-rotating	up to 400HP	Budget - COMKIT1 Bullhorn style Admiral-OBKIT1 Bullhorn style Budget - COMKIT5 Front-mount style Admiral- OBKIT5 Front-mount style	
		2 Stroke Twin counter-rotating	up to 600HP	Budget - COMKIT1- <b>PRO</b> Bullhorn style Admiral-OBKIT1 Bullhorn style	
HONDA	PRE-2006	4 Stroke Single	75HP-90HP	Budget - COMKIT1- <b>HONDA</b> Bullhorn style Admiral-OBKIT1- <b>HONDA</b> Bullhorn style Budget - COMKIT5 Front-mount style Admiral- OBKIT5 Front-mount style	
		4 Stroke single	100HP-200HP	Budget - COMKIT1 Bullhorn style Admiral-OBKIT1 Bullhorn style Budget - COMKIT5 Front-mount style Admiral- OBKIT5 Front-mount style	Note: The <b>130HP</b> requires the use of the Honda version
		4 Stroke Single	225HP	Budget - COMKIT1- <b>PRO</b> Bullhorn style Admiral-OBKIT1 Bullhorn style	
		4 Stroke Twin counter-rotating	up to 400HP	Budget - COMKIT1 Bullhorn style Admiral-OBKIT1 Bullhorn style Budget - COMKIT5 Front-mount style Admiral- OBKIT5 Front-mount style	Note - if using twin <b>75HP, 90HP or 130HP</b> motors then Honda version required
		4 Stroke Twin counter-rotating	twin 225HP	Budget - COMKIT1- <b>PRO</b> Bullhorn style Admiral-OBKIT1 Bullhorn style	
	POST-2006	4-Stroke single	75-90HP	Budget - COMKIT1 Bullhorn style Admiral-OBKIT1 Bullhorn style Budget - COMKIT5 Front-mount style Admiral- OBKIT5 Front-mount style	
		4-Stroke single	115HP	Budget - COMKIT1- <b>HONDA</b> Bullhorn style Admiral-OBKIT1- <b>HONDA</b> Bullhorn style Budget - COMKIT5 Front-mount style Admiral- OBKIT5 Front-mount style	
		4-Stroke single	135HP-200HP	Budget - COMKIT1 Bullhorn style Admiral-OBKIT1 Bullhorn style Budget - COMKIT5 Front-mount style Admiral- OBKIT5 Front-mount style	
		4-Stroke single	225HP	Budget - COMKIT1- <b>PRO</b> Bullhorn style Admiral-OBKIT1 Bullhorn style	
		4 Stroke Twin counter-rotating	up to 400HP	Budget - COMKIT1 Bullhorn style Admiral-OBKIT1 Bullhorn style Budget - COMKIT5 Front-mount style Admiral- OBKIT5 Front-mount style	<b>Note - if using twin 115HP motors then Honda version required</b>
		4 Stroke Twin counter-rotating	twin 225HP	Budget - COMKIT1- <b>PRO</b> Bullhorn style Admiral-OBKIT1 Bullhorn style	
		4-Stroke single	30 - 40HP	Budget - COMKIT1 Bullhorn style Admiral-OBKIT1 Bullhorn style	
YAMAHA	ALL YEARS	4-Stroke single	50-70HP PLUS 80B	Budget - COMKIT1 Bullhorn style Admiral-OBKIT1 Bullhorn style Budget - COMKIT5 Front-mount style Admiral- OBKIT5 Front-mount style	<b>Note: The transom clamps on these motors must be cut off to allow full tilt of the steering system which would otherwise interfere on the clamps. These clamps will interfere on ALL makes and brands of bullhorn or front-mount steering cylinders.</b>
		4-Stroke single	80A-90HP PLUS 115B	Budget - COMKIT1- <b>HONDA</b> Bullhorn style Admiral-OBKIT1- <b>HONDA</b> Bullhorn style Budget - COMKIT5 Front-mount style Admiral- OBKIT5 Front-mount style	<b>Note: The transom clamps on these motors must be cut off to allow full tilt of the steering system which would otherwise interfere on the clamps. These clamps will interfere on ALL makes and brands of bullhorn or front-mount steering cylinders.</b>
		4-Stroke single	100-200HP	Budget - COMKIT1 Bullhorn style Admiral-OBKIT1 Bullhorn style Budget - COMKIT5 Front-mount style Admiral- OBKIT5 Front-mount style	
		4-stroke single	200-300HP	Budget - COMKIT1- <b>PRO</b> Bullhorn style Admiral-OBKIT1 Bullhorn style	

# HYDRIVE MODEL SELECTION - OUTBOARD MOTORS ONLY

**Note:- The model COMKIT6 can be used in place of the COMKIT1 on all SINGLE motors up to 150HP maximum.**

**Optimum performance range for comfortable wheel effort on COMKIT6 is 40HP - 120HP**

**The same version should be used as indicated in the listed options - Honda, Mercury etc.**

BRAND	YEAR	MOTOR	HP	HYDRIVE KIT OPTIONS	NOTES
YAMAHA	ALL YEARS	4-stroke single	350HP	Admiral OBKIT1-HP OR OBKIT1-HP-XT	High performance unit required on 350HP
		4 Stroke Twin counter-rotating	50-70HP PLUS 80B	Budget - COMKIT1 Bullhorn style Admiral-OBKIT1 Bullhorn style Budget - COMKIT5 Front-mount style Admiral- OBKIT5 Front-mount style	<i>Note: The transom clamps on these motors must be cut off to allow full tilt of the steering system which would otherwise interfere on the clamps. These clamps will interfere on ALL makes and brands of bullhorn or front-mount steering cylinders.</i>
		4 Stroke Twin counter-rotating	80A-90HP	Budget - COMKIT1-HONDA Bullhorn style Admiral-OBKIT1-HONDA Bullhorn style Budget - COMKIT5 Front-mount style Admiral- OBKIT5 Front-mount style	<i>Note: The transom clamps on these motors must be cut off to allow full tilt of the steering system which would otherwise interfere on the clamps. These clamps will interfere on ALL makes and brands of bullhorn or front-mount steering cylinders.</i>
		4-Stroke Twin counter rotating	100-200HP	Budget - COMKIT1 Bullhorn style Admiral-OBKIT1 Bullhorn style Budget - COMKIT5 Front-mount style Admiral- OBKIT5 Front-mount style	
		4 Stroke Twin counter-rotating	200-300HP	Budget - COMKIT1-PRO Bullhorn style Admiral-OBKIT1 Bullhorn style	
		4 Stroke Twin counter-rotating	350HP	Admiral OBKIT1-HP OR OBKIT1-HP-XT	High performance unit required on 350HP
		2-Stroke single	115-200HP	Budget - COMKIT1 Bullhorn style Admiral-OBKIT1 Bullhorn style Budget - COMKIT5 Front-mount style Admiral- OBKIT5 Front-mount style	
		2-Stroke single	50-90HP	Budget - COMKIT1-MERC Bullhorn style Admiral-OBKIT1-MERC Bullhorn style Budget - COMKIT5 Front-mount style Admiral- OBKIT5 Front-mount style	<i>Note- Merc versions required on bullhorn type steering for these motors</i>
MERCURY	ALL YEARS	VERADO SINGLE	135-175HP	Budget - COMKIT1 Bullhorn style Admiral-OBKIT1 Bullhorn style Budget - COMKIT5 Front-mount style Admiral- OBKIT5 Front-mount style	
		VERADO DUAL Counter rotating	135-175HP	Budget - COMKIT1 Bullhorn style Admiral-OBKIT1 Bullhorn style Budget - COMKIT5 Front-mount style Admiral- OBKIT5 Front-mount style	
		OPTIMAX SINGLE	75-115HP	Budget - COMKIT1-MERC Bullhorn style Admiral-OBKIT1-MERC Bullhorn style Budget - COMKIT5 Front-mount style Admiral- OBKIT5 Front-mount style	<i>Note- Merc versions required on bullhorn type steering for these motors</i>
		OPTIMAX SINGLE	135-200HP	Budget - COMKIT1 Bullhorn style Admiral-OBKIT1 Bullhorn style Budget - COMKIT5 Front-mount style Admiral- OBKIT5 Front-mount style	
		OPTIMAX DUAL counter rotating	75-115HP	Budget - COMKIT1-MERC Bullhorn style Admiral-OBKIT1-MERC Bullhorn style Budget - COMKIT5 Front-mount style Admiral- OBKIT5 Front-mount style	<i>Note- Merc versions required on bullhorn type steering for these motors</i>
		OPTIMAX DUAL counter rotating	135-200HP	Budget - COMKIT1 Bullhorn style Admiral-OBKIT1 Bullhorn style Budget - COMKIT5 Front-mount style Admiral- OBKIT5 Front-mount style	
		OPTIMAX SINGLE	225HP	Budget - COMKIT1-PRO Bullhorn style Admiral-OBKIT1 Bullhorn style	
		OPTIMAX DUAL counter rotating	225HP	Budget - COMKIT1-PRO Bullhorn style Admiral-OBKIT1 Bullhorn style	
		4-Stroke single	60-115HP <b>NEW 150HP USES STANDARD ARM</b>	Budget - COMKIT1-MERC Bullhorn style Admiral-OBKIT1-MERC Bullhorn style Budget - COMKIT5 Front-mount style Admiral- OBKIT5 Front-mount style	<i>Note- Merc versions required on bullhorn type steering for these motors - Except new 150HP uses standard tiller arm</i>

# HYDRIVE MODEL SELECTION - OUTBOARD MOTORS ONLY

**Note:- The model COMKIT6 can be used in place of the COMKIT1 on all SINGLE motors up to 150HP maximum.**  
**Optimum performance range for comfortable wheel effort on COMKIT6 is 40HP - 120HP**  
**The same version should be used as indicated in the listed options - Honda, Mercury etc.**

BRAND	YEAR	MOTOR	HP	HYDRIVE KIT OPTIONS	NOTES
MERCURY	ALL YEARS	4-Stroke DUAL Counter rotating	60-115HP - <b>see above for 150HP</b>	Budget - COMKIT1- <b>MERC</b> Bullhorn style Admiral-OBKIT1- <b>MERC</b> Bullhorn style Budget - COMKIT5 Front-mount style Admiral- OBKIT5 Front-mount style	Note- Merc versions required on bullhorn type steering for these motors - <b>Except new 150HP uses standard tiller arm</b>
		2-Stroke single	40-200HP	Budget - COMKIT1 Bullhorn style Admiral-OBKIT1 Bullhorn style Budget - COMKIT5 Front-mount style Admiral- OBKIT5 Front-mount style	
		2-Stroke single	EFI 250HP	Budget - COMKIT1- <b>PRO</b> Bullhorn style Admiral-OBKIT1 Bullhorn style	
		2-Stroke single	40-90HP	Budget - COMKIT1 Bullhorn style Admiral-OBKIT1 Bullhorn style Budget - COMKIT5 Front-mount style Admiral- OBKIT5 Front-mount style	
		2-Stroke single	Bigfoot 40-60HP	Budget - COMKIT1 Bullhorn style Admiral-OBKIT1 Bullhorn style Budget - COMKIT5 Front-mount style Admiral- OBKIT5 Front-mount style	
		2-Stroke DUAL Counter rotating	40-200HP	Budget - COMKIT1 Bullhorn style Admiral-OBKIT1 Bullhorn style Budget - COMKIT5 Front-mount style Admiral- OBKIT5 Front-mount style	
		2-Stroke DUAL Counter rotating	EFI 250HP	Budget - COMKIT1- <b>PRO</b> Bullhorn style Admiral-OBKIT1 Bullhorn style	
		2-Stroke DUAL Counter rotating	40-90HP	Budget - COMKIT1 Bullhorn style Admiral-OBKIT1 Bullhorn style Budget - COMKIT5 Front-mount style Admiral- OBKIT5 Front-mount style	
		2-Stroke DUAL Counter rotating	Bigfoot 40-60HP	Budget - COMKIT1 Bullhorn style Admiral-OBKIT1 Bullhorn style Budget - COMKIT5 Front-mount style Admiral- OBKIT5 Front-mount style	
SUZUKI	ALL YEARS	4-stroke single	40-140HP	Budget - COMKIT1 Bullhorn style Admiral-OBKIT1 Bullhorn style Budget - COMKIT5 Front-mount style Admiral- OBKIT5 Front-mount style	<b>Note: some older models may require a spacer to fit into the recess under the tiller arm. These are available on request. Current motors do not require them.</b>
		4-Stroke single	150-200HP	Budget - COMKIT1 Bullhorn style Admiral-OBKIT1 Bullhorn style Budget - COMKIT5 Front-mount style Admiral- OBKIT5 Front-mount style	
		4-Stroke single	225-250HP	Budget - COMKIT1- <b>PRO</b> Bullhorn style Admiral-OBKIT1 Bullhorn style	
		4-Stroke DUAL Counter rotating	40-140HP	Budget - COMKIT1 Bullhorn style Admiral-OBKIT1 Bullhorn style Budget - COMKIT5 Front-mount style Admiral- OBKIT5 Front-mount style	<b>Note: some older models may require a spacer to fit into the recess under the tiller arm. These are available on request. Current motors do not require them.</b>
		4-Stroke DUAL Counter rotating	150-200HP	Budget - COMKIT1 Bullhorn style Admiral-OBKIT1 Bullhorn style Budget - COMKIT5 Front-mount style Admiral- OBKIT5 Front-mount style	
		4-Stroke DUAL Counter rotating	225-250HP	Budget - COMKIT1- <b>PRO</b> Bullhorn style Admiral-OBKIT1 Bullhorn style	
TOHATSU	ALL YEARS	SINGLE	60-90HP	Budget - COMKIT1- <b>MERC</b> Bullhorn style Admiral-OBKIT1- <b>MERC</b> Bullhorn style Budget - COMKIT5 Front-mount style Admiral- OBKIT5 Front-mount style	<b>Note- Merc versions required on bullhorn type steering for these motors</b>
		SINGLE	100-200HP	Budget - COMKIT1 Bullhorn style Admiral-OBKIT1 Bullhorn style Budget - COMKIT5 Front-mount style Admiral- OBKIT5 Front-mount style	
		DUAL Counter rotating	60-90HP	Budget - COMKIT1- <b>MERC</b> Bullhorn style Admiral-OBKIT1- <b>MERC</b> Bullhorn style Budget - COMKIT5 Front-mount style Admiral- OBKIT5 Front-mount style	<b>Note- Merc versions required on bullhorn type steering for these motors</b>
		DUAL Counter rotating	100-200HP	Budget - COMKIT1 Bullhorn style Admiral-OBKIT1 Bullhorn style Budget - COMKIT5 Front-mount style Admiral- OBKIT5 Front-mount style	